

PRO-2000 X6 Panels

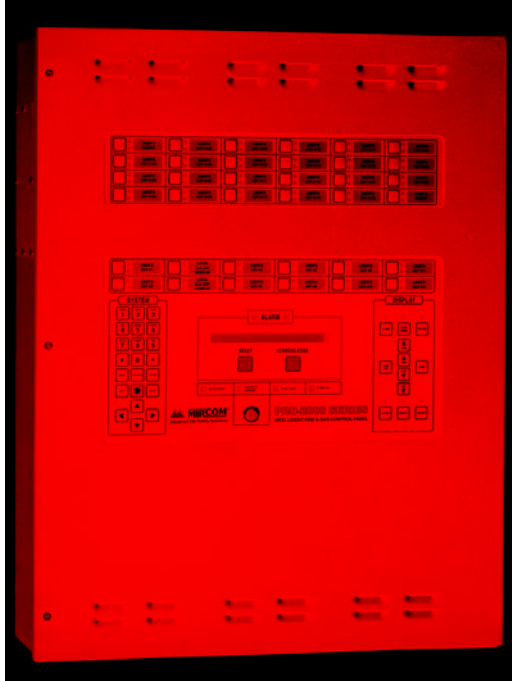

Description

The PRO-2000 X6 panels are microprocessor-based fire alarm control units, suitable for medium to large fire detection and suppression applications. Larger applications can be covered using additional panels in a master/slave network configuration.

There are three types of X6 panels available: the X6S, the X6E and the X6M.

The X6S panel is the standard model. It has a built in LCD display (2 line by 40 characters) and associated controls and indicators. It also has 24 programmable indicators and 12 programmable pushbuttons.

The X6E panel has the same features as the X6S plus a matrix of 48 additional programmable indicators and 24 additional programmable pushbuttons.

The X6M panel has the same features as the X6S plus a geographic mimic panel containing up to 144 indicators. The geographic mimic also supports 72 pushbuttons for special applications. The geographic mimic provides a graphical representation of the protected areas. When new events are displayed on the LCD, their location can be identified rapidly by the appropriate indicators on the geographic mimic.

Features

- Up to 3600 local detection/control devices
- Max. 10000 networked detection/control devices
- Integrated gas detection
- Agent releasing service
- Support for 2-wire addressable devices
- Support for conventional 2-wire initiating devices
- Support for notification circuits
- Support for multi-panel networking
- One man walk test
- Battery backed-up real time clock and event log with built-in battery charger
- Independent ground fault detection circuits on each interface card for easy ground fault tracking
- Wall mount enclosure equivalent to NEMA 2

The following types of devices are supported by the X6 panels:

Addressable devices:

- Smoke detectors, heat detectors, monitor modules and control modules

Conventional initiating devices:

- Non-shorting detectors (Heat detectors, smoke detectors, etc...)
- Shorting devices (Pull-stations, Abort pushbuttons, Manual release-pull stations)

Conventional notification devices:

- Unsupervised NO or NC relay output
- Supervised and powered relay output

The X6 panels support communication and networking functions via different physical interfaces such as RS-232 (to connect printers, PLC's or PC's), RS-422 (panel networking), or RS-485.

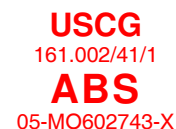

All PRO-2000 Series panels (X6, X2 and X0) may be connected together in a master/slave configuration (up to 32 panels). The X0 is only a repeater panel (remote annunciator).

The X6 panels can be configured to support up to 6 interface cards. The interface cards can be any of the following:

- Addressable detector interface card (Smoke/heat detectors, monitor modules, control modules)
- Supervised input card (Conventional detector, shorting and non-shorting devices)
- Supervised relay card (Supervised outputs and dry contacts)
- Communication card (Networked configurations)

All the events occurring on the X6 panels (alarms, troubles, etc...) are communicated to the user using a 2-line by 40-character Liquid Crystal Display (LCD). There are four control sections associated with the LCD: Display section, acknowledgment section, System section and user defined section.

The Display section gives the user an easy way of accessing the system's display list: Alarm, Supervisory, Trouble, Status, Isolate and Service.

The acknowledgment section enables the user to handle the new events and to clear the obsolete events using the associated buttons (Acknowledge and Reset). Access to these functions can only be obtained via a control key thus preventing unauthorized use of the system.

The System section is used mainly for maintenance activities and is used to access various functions of the X6 panel. The Service and Isolate mode as well as the one man walk test mode may be accessed through the System section's menu.

The user defined section consists of a group of configurable indicators and buttons. There are 24 indicators and 12 buttons. Special functions such as fan control or pump control can be assigned to the configurable indicators and buttons.

Technical Specifications

Electrical Specifications

Primary AC Power Supply	
Voltage	115 or 220 VAC
Frequency	50 or 60 Hz
Maximum power	125 Watts
Master Alarm and Trouble Relays	
Contact rating	2 A @30 VDC
Communication Modules	
Number of sockets for communication modules	2*
Interface Cards	
Number of connectors for expansion cards	6

* One socket is used for local LCD connection.

Physical Specifications

X6S Panel
30"H x 24"W x 7"D (762mm x 610mm x 178mm)
X6E Panel
30"H x 24"W x 7"D (762mm x 610mm x 178mm)
X6M Panel
41"H x 24"W x 7"D (1041mm x 610mm x 178mm)

Typical Application Diagram

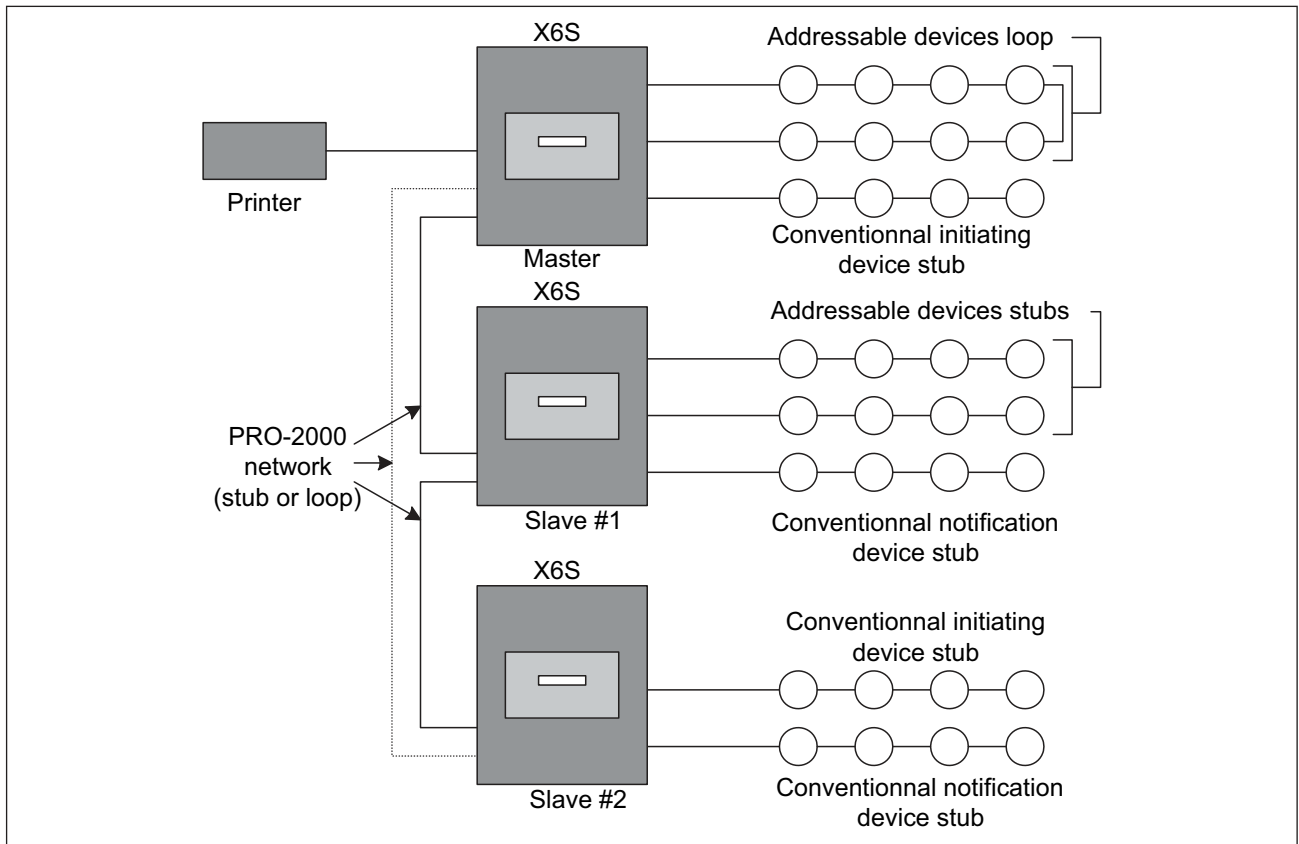

X6 Panel Block Diagram

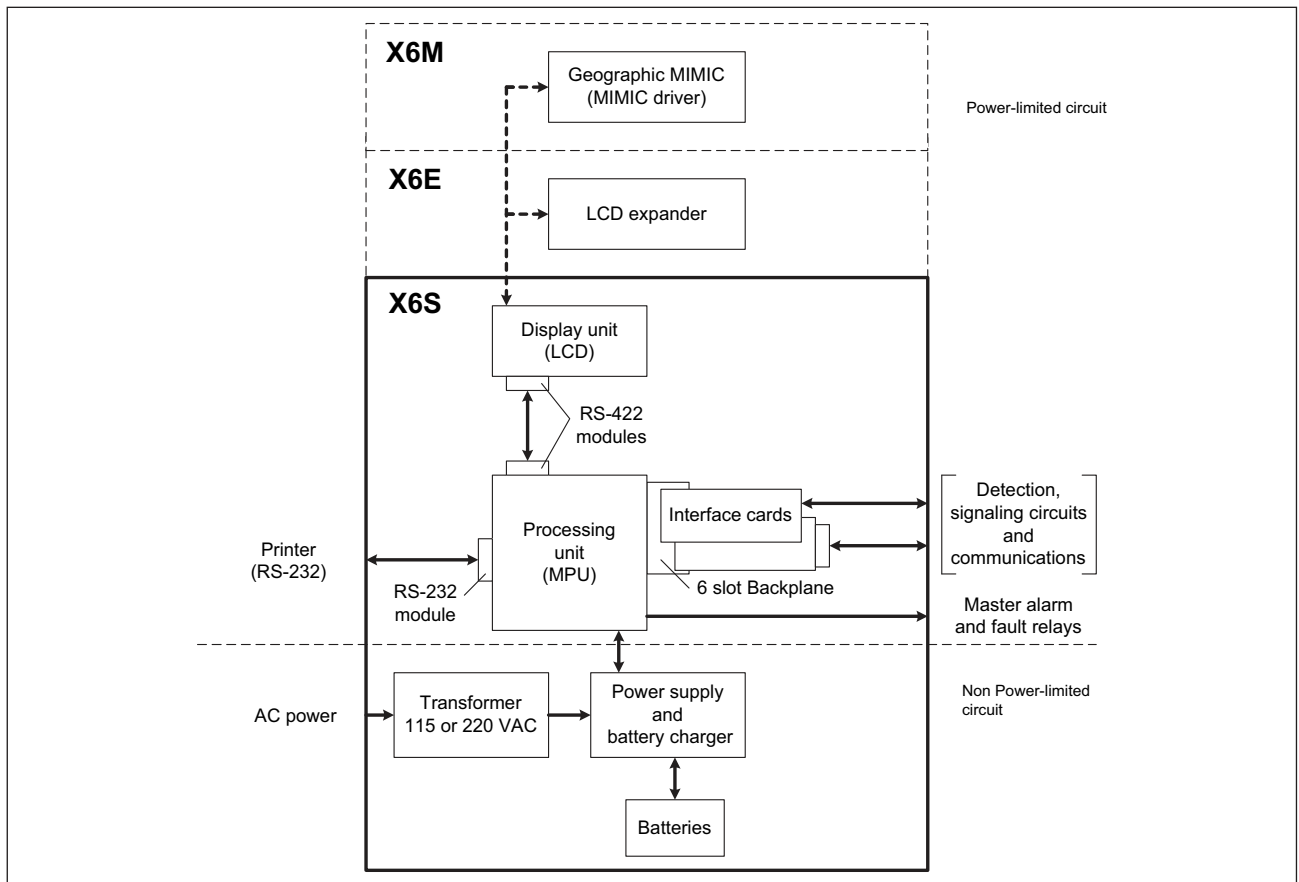

Ordering Information

